



ACE Band Screen 1500

Waste Water Experience
& Innovation



ACE Band Screen 1500

Waste Water Experience
& Innovation



CENTRE FLOW BAND SCREEN FOR AUTOMATIC REMOVAL OF SOLIDS FROM FLOW IN TWO DIMENSIONS.

FEATURES AND BENEFITS

Overview

- Compliant with WIMES 5.03
- Robust stainless steel construction with durable Polypropylene 30% glass filled UV stabilised black screen panels
- All maintenance carried out in situ
- Proven track record, installed in many water PLC's.

Operation

- In and out flow to increase screening capture ratio
- High Screening capture ratio - 79% - 5mm screening
- Screen perforations available - 5mm, 3mm and 2mm (other sizes available on application)
- Efficient deluge cleaning system with intergrated self-adjusting scraper mechanism
- Low headloss.

ALL maintenance can be carried out in situ supporting totex

- Main belt articulated links carry the perforated screen panels
- Quick release screen panels - simple removal and replacement
- Cartridge rollers - self extracting for ease of replacement
- Removable seal plates - for ease of main seal replacement
- Interlocked hinged covers for ease of access and inspection.



Installation

Suitable for Channels*

Width - 750mm to 1200mm

Depth - 1000mm to 2000mm

Maximum depth of flow 1000mm*

Discharge height (from coping)* 364mm to 1404mm

*for installations and requirements outside of these parameters, please contact Haigh Engineering.

TESTED AT THE
NATIONAL
SCREEN
EVALUATION
FACILITY
CHESTER-LE-
STREET

FLOW CONFIGURATION

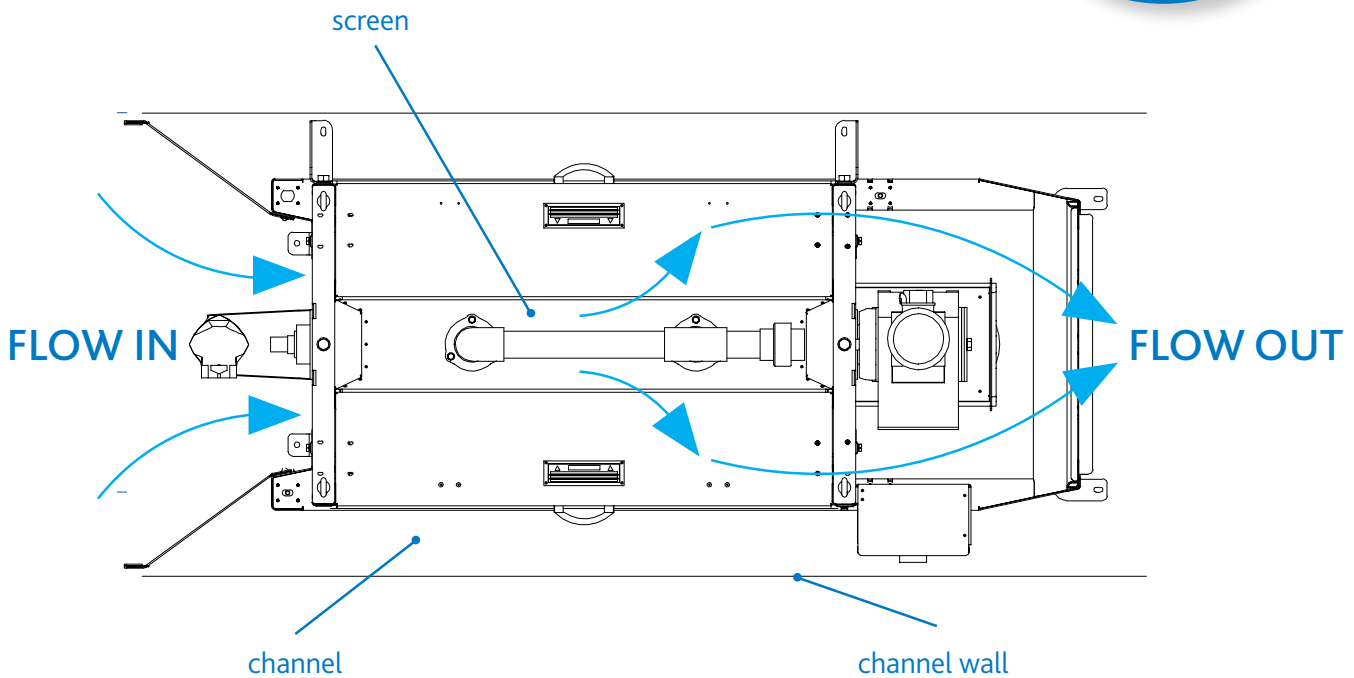

KEY FACTS

Services required: 4 l/s wash water at 3 bar while running.

Typical electric motor drive size: 0.55kW.

CAPACITIES

Minimum channel width	Screen hole size	Capacity
750mm	5mm	150 l/s
800mm	5mm	150 - 200 l/s
750mm	3mm	130 l/s
750mm	2mm	100 l/s

INSTALLATION DRAWING

Notes

To configure ACE Bandscreen the following dimensions are required.

"X" = 364 minimum - 1404 maximum

"Y" = 1000 minimum - 2000 maximum (depth of channel)

"Z" = 750 minimum - 1200 maximum (channel width)

For installations and requirements with dimensions outside of the above values, please contact Haigh Engineering.

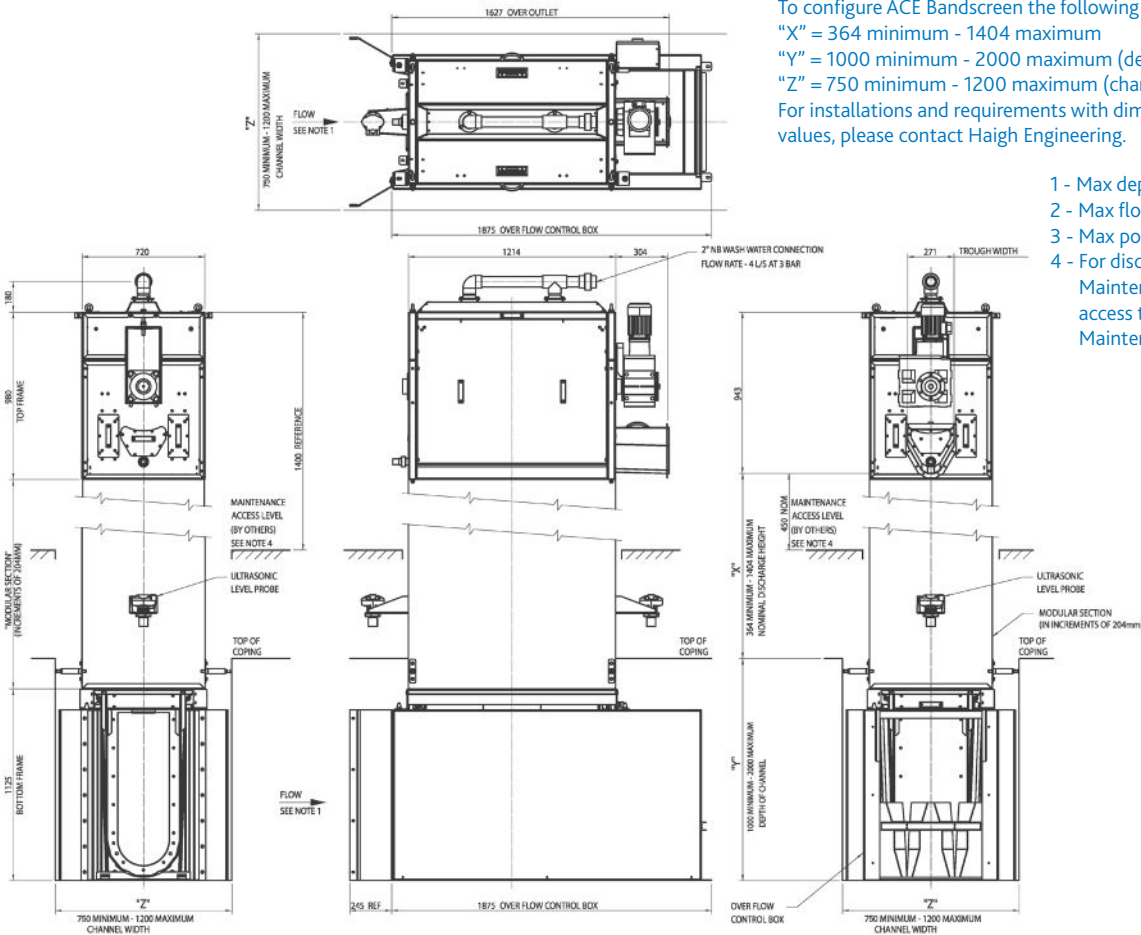

- 1 - Max depth of flow is 1000mm
- 2 - Max flow rate - 200 l/s
- 3 - Max population - 12,000
- 4 - For discharge height ("X") above 450mm
Maintenance platform is required to access top frame.
Maintenance access platform by others.

SALES AND SERVICE SUPPORT



Haigh Engineering has a UK wide dedicated sales force who specialise in knowing how to bring added value to your works such as reducing civil costs and the need for site washwater and cutting screenings skip and transport costs.

Your local Sales Manager will be pleased to discuss your particular requirements and options for Haigh equipment to suit your works. If you decide to proceed with a Haigh installation a dedicated Contracts Engineer will be appointed to your project to oversee it from start to finish.

Installation can be undertaken by Haigh trained engineers and electricians who have in many cases served their apprenticeships with the Company - nobody knows Haigh products better than we do.



www.haigh.co.uk

The Haigh Engineering Company Ltd

Alton Road, Ross-on-Wye, Herefordshire HR9 5NG

Tel: +44(0)1989 763 131

info@haigh.co.uk



Made in UK

